

**KENDRION** INDUSTRIAL  
WE MAGNETISE THE WORLD



*greensigned*  
BY BINDER

INDUSTRIAL DRIVE SYSTEMS **BINDER**

Company presentation  
Industrial Drive Systems  
Michael Bernhard, Villingen, 8 October 2015

**KENDRION** INDUSTRIAL  
WE MAGNETISE THE WORLD

*greensigned*  
BY BINDER



## Agenda

- IDS company presentation
- Strategic markets and direction
- Business unit summary
- Mid-term planning (2015 – 2018)
- Greensigned and Kobra
- Further important developments

INDUSTRIAL DRIVE SYSTEMS

2

### Product overview Division Industrial

INDUSTRIAL		
<p>INDUSTRIAL MAGNETIC SYSTEMS</p>  <ul style="list-style-type: none"> <li>Single stroke solenoids</li> <li>Rotary solenoids</li> <li>Door holding solenoids</li> <li>Holding magnets</li> <li>Solenoid valves</li> <li>Explosion-proof solenoids</li> <li>Elevator solenoids</li> <li>Customer-specific solenoids</li> </ul>	<p>INDUSTRIAL CONTROL SYSTEMS</p>  <ul style="list-style-type: none"> <li>Valve, valve units</li> <li>Linear solenoids</li> <li>Rotary solenoids</li> <li>Holding solenoids</li> <li>Human machine interfaces</li> <li>Control and I/O systems</li> <li>Software</li> <li>Functional mechatronic units</li> <li>Customer-specific solutions</li> </ul>	<p>INDUSTRIAL DRIVE SYSTEMS</p>  <ul style="list-style-type: none"> <li>Permanent-magnet brakes</li> <li>Pneumatic clutches</li> <li>Clutch brake units</li> <li>Spring-applied brakes</li> <li>Electronic accessories</li> <li>Solutions for hazardous areas</li> <li>Micro brakes &amp; clutches</li> <li>Magnet powder clutches</li> <li>Customer-specific solutions</li> </ul>

INDUSTRIAL DRIVE SYSTEMS

3

### Global presence - locations Industrial Drive Systems



INDUSTRIAL DRIVE SYSTEMS

4







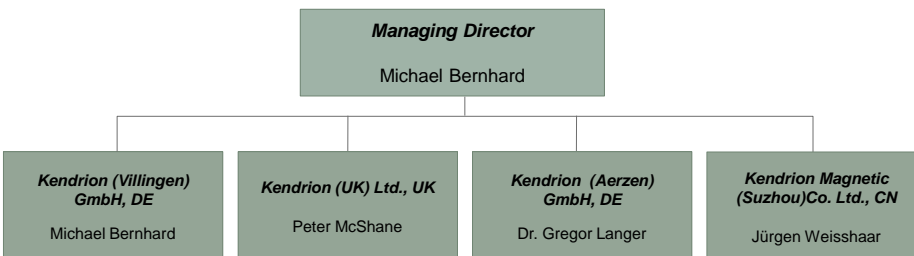

### IDS locations with direct employees

				
<i>Kendrión (Villingen) GmbH, DE</i>	<i>Kendrión (Aerzen) GmbH, DE</i>	<i>Kendrión (UK) Ltd., Bradford / UK</i>	<i>Kendrión Magnetic (Suzhou), CN</i>	<i>Kendrión (Italy) Srl, Torino / IT</i>
<b>Sales &amp; Services</b>	<b>Sales &amp; Services</b>	<b>Sales &amp; Service</b>	<b>Sales &amp; Service</b>	<b>Sales</b>
<b>Production</b>	<b>Production</b>		<b>Production</b>	
<ul style="list-style-type: none"> <li>• PM brakes (2 lines)</li> <li>• SA brakes (1 line)</li> <li>• KOBRA-A line</li> <li>• Electronic modules (outsourced / R&amp;D)</li> <li>• Airflex clutches</li> </ul>	<ul style="list-style-type: none"> <li>• small clutches &amp; brakes</li> <li>• Magnetic particle clutches and brakes</li> <li>• special customized electromagnctic applications</li> </ul>		<ul style="list-style-type: none"> <li>• SA brakes (elevator brakes)</li> <li>• Kobra-S brake for Asia and US market will start in Q1/2016</li> </ul>	
Employees: 204	Employees: 50	Employees: 8	Employees: 20	Employees: 1

### Organisation Industrial Drive Systems



**Product overview – your full-range provider for electromagnetic brakes & clutches**

<p>Permanent magnet brakes</p> <ul style="list-style-type: none"> <li>▪ Classic PM-brakes</li> <li>▪ High torque brakes</li> </ul> 	<p>Spring-applied brakes</p> <ul style="list-style-type: none"> <li>▪ Safety brakes</li> <li>▪ Elevation brakes</li> <li>▪ Single-disc brakes</li> </ul> 	<p>Explosion protected solutions</p> <ul style="list-style-type: none"> <li>▪ EEX Line</li> </ul> 
<p>Airflex – pneumatic brakes &amp; clutches</p> 	<p>Electronical devices</p> 	<p>Operating current executed brakes and clutches</p> 
<p>Magnetic particle clutches and brakes</p> 	<p>Clutch-brake units</p> 	<p>Customised solutions</p> 



INDUSTRIAL DRIVE SYSTEMS

7

**Kendrion IDS - focused industries**



Automation & Robotics



Medical



Transport



Safety & Comfort



Renewable energies



Consumer appliances



Machine building



Entertainment & Leisure time



Explosion hazardous areas

INDUSTRIAL DRIVE SYSTEMS

8



**Customer references**



INDUSTRIAL DRIVE SYSTEMS

9



**Quality from Kendrion**



**Certificates:**

- ISO 9001 : 2000
- Atex 100A
- CSA and UL-licence (for several devices)
- ISO 14001

INDUSTRIAL DRIVE SYSTEMS

10

### Turnover IDS Group 2004 - 2014

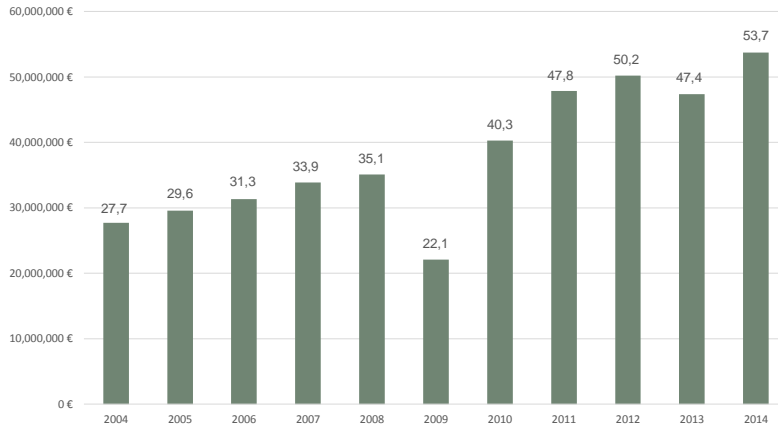

### Strategic markets Market attractiveness

Globally, elevator brakes and servo motors brakes (> 0.5 kW) have the highest overall market attractiveness scores

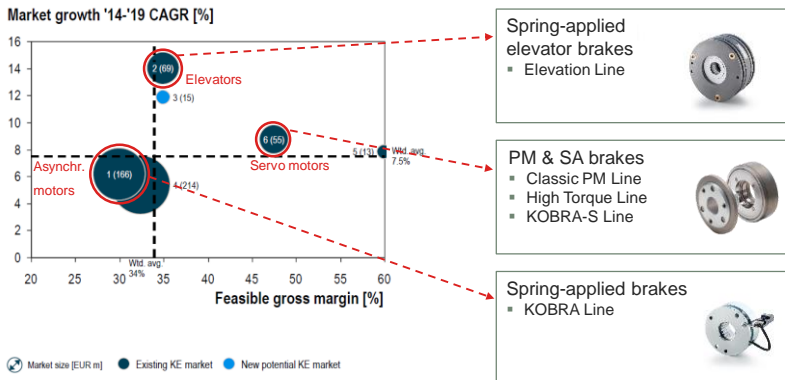

## Strategic direction 2016 – 2018

- **Market segment objectives 2016 - 2018**
  - Achieve market share in SAB market of 5% (does not include replacement of brakes manufactured by motor companies)
  - Achieve market share of 10% in the elevator market
  - Achieve market share of 50% in the servo motor market (without acquisition)
- **Development direction**
  - Product portfolio
  - M&A (USA and Asia)
  - Enhance product portfolio, e.g. planetary gearboxes, small motors, feedback systems
  - Develop towards mechatronics system supplier, e.g. motor-gearbox-clutch/brake combination

## Business unit summary

- Realignment of global sales structure
- VS production automation process
- VS implementation APS/BDE/MDE (intelligent production control)
- Product portfolio (further new developments and streamlining)
- Realign Kobra marketing strategy
- Strengthen sales force in China (KOBRA, PM, elevator)
- Acquisition in USA and Asia

### What is greensigned?

Kendrion's greensigned products achieve excellent environmental performance combined with maximum energy efficiency



greensigned is part of our long-term strategy for sustainable products

### Benefits of „greensigned“

... for the Business Units?	... for the Kendrion Brand?
Long-term opportunity to improve market position	
Development of a contemporary sustainable image	
Strengthened confidence in Kendrion as long-term strategical partner	
Secures future revenues with increasingly environmentally aware customers	Positioning Kendrion as responsible brand
Positioning as innovative partner	greensigned perfectly carries the brand values: ambitious, reliable, global, solution-driven, innovative.
Differentiation from competitors	Proof of Corporate Social Responsibility
Employer Branding: stronger attraction for highly qualified employees	
Employer Branding: existing staff is proud to work for such an responsible employer	



### Pioneer product of greensigned-strategy: KOBRA energy-saving spring-applied brake

KL100/KL110 KOBRA Line, without IP-protection (open housing)

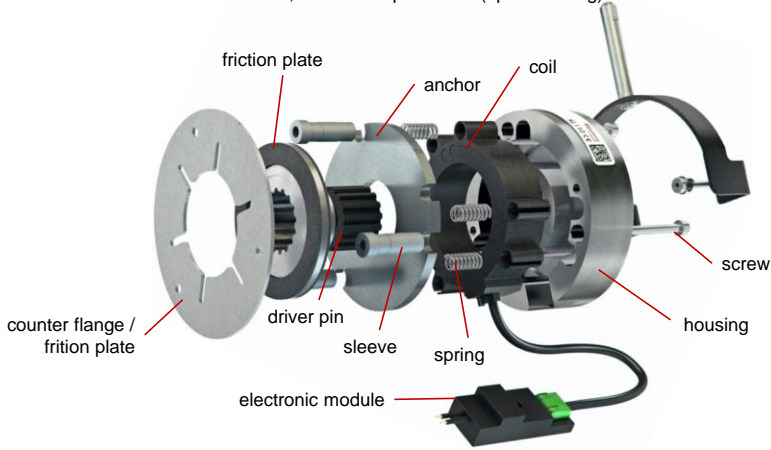

### The KOBRA performance triangle

Based on the requirements of the customers' specific application, it is up to them to decide where to place the brake within the performance triangle made up of torque, lifecycle and energy savings.

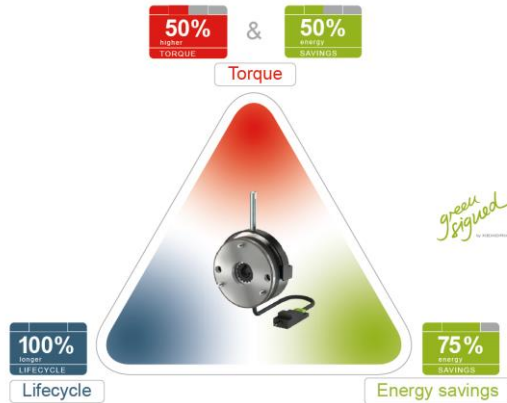

**Further important developments:  
Schindler spring-applied brake for elevators, Kendrion Suzhou**

Schindler Brake, frame size 29, 33, 40



**Sylomer 300 noise damper sizes 29, 33 and 40**

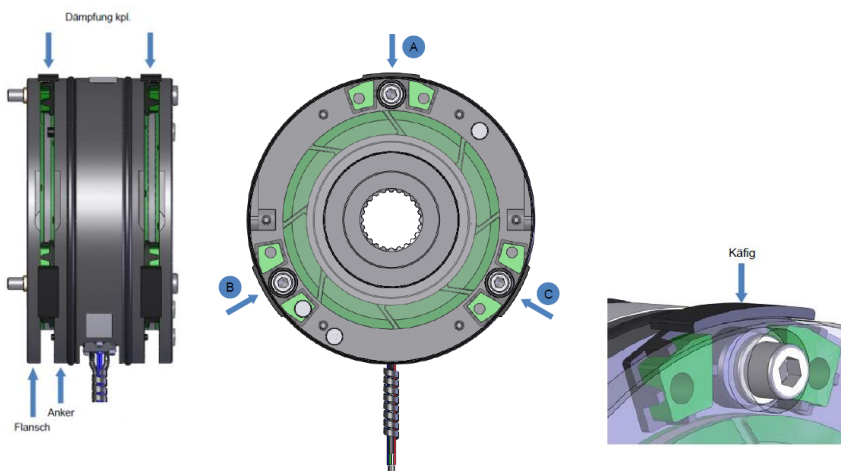

**Noise measurement BG 40 2 x 700 Nm**

Requirement: noise level below 65dBA(fast) in the temperature range from 10 to 35°C

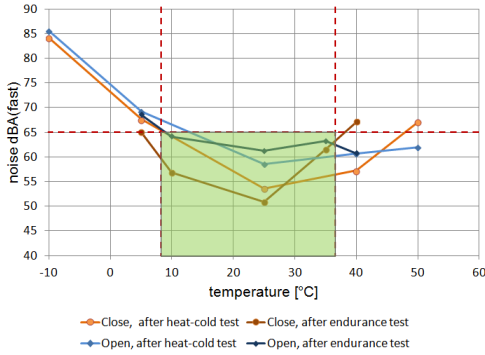

- Air gap
- MGB = 0,40mm-0,50mm
  - MGB1 = 0,45mm-0,50mm